

# ***Fieldpiece***®

## Vacuum Pump with RunQuick® Oil Change System

### **OPERATOR'S MANUAL**

Models VP633

VP833

VPX33

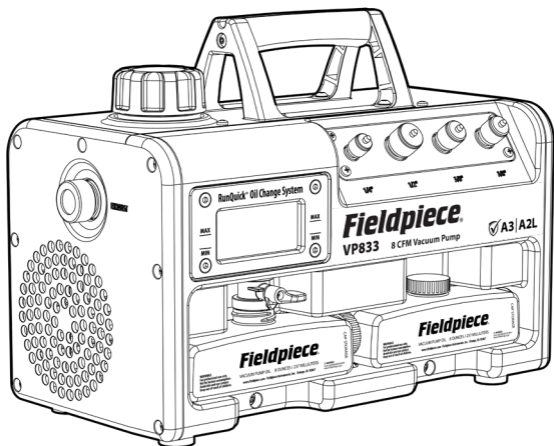

# Contents

**Important Notice** . . . . . 4

**Safety First!** . . . . . 5

**Safety Information.** . . . . . 8

Vacuum Pump Protection

Setup

IEC Power Cord with Screw Locks

Grounding Instructions

**Specifications** . . . . . 10

**Certifications** . . . . . 11

**Description** . . . . . 12

What's Included

Features

**Tech Tips** . . . . . 14

General

Cold Weather Starts

Setup

**Operation.** . . . . . 16

RunQuick® Oil Change System

Evacuation with a 4 Port Manifold

Evacuation with a 3 Port Manifold

Direct Evacuation

Oil Change Procedure

Dynamic Vacuum Measurement

Remote Exhaust

Gas Ballast Valve Switch

LED Indicators

**Maintenance.** . . . . . 30

General

Storage

Vacuum Isolation Test

Oil Window Cleaning

**Troubleshooting** . . . . . 32

**Limited Warranty** . . . . . 34

Obtaining Service

# Important Notice

This is not a consumer machine. Only qualified personnel trained in service and installation of A/C and/or refrigeration equipment shall use this vacuum pump.

This vacuum pump is used for evacuating (drying) refrigerant lines. Fieldpiece's recovery machine is available for recovering refrigerant.

Read and understand this operator's manual in its entirety before using to prevent injury or damage to you or equipment.



**Read operator manual.**



**Wear hearing protection.**



**Do not use in rain.**



**Replace cable if damaged.**

# Safety First!

**RISK OF EXPLOSION. DANGER:** This machine is for use only by qualified and certified technicians in the safe use, handling, and transporting of refrigerants. Please refer to flammable refrigerant safety guides, regional codes and legislation for more information. Read and understand this operator's manual in its entirety before using to prevent injury or damage to you or equipment.

## **⚠️ WARNINGS – failure to heed these hazards and actions while using this device can result in serious injury or death:**

1. **WARNING: EXPLOSION HAZARD.** Outside of the Temporary Hazard Zone, ensure device(s) power is switched OFF ( 0 ) before connecting and locking the power cord onto the unit(s). Connect any other equipment and connect to the main power.
2. **WARNING: EXPLOSION HAZARD.** Always use a correctly grounded outlet.
3. **WARNING: EXPLOSION HAZARD.** Ensure power and extension cords are in good working condition to prevent shock and spark hazards.
4. **WARNING: EXPLOSION HAZARD.** Do not operate the unit in excessively dusty environments or environments where conductive dust is to be expected.
5. **WARNING: EXPLOSION HAZARD.** Do not connect or disconnect when energized.
6. **WARNING: EXPLOSION HAZARD.** Ensure area around machine is free of debris that could enter air vents and fan and cause accidental sparking.
7. **WARNING: EXPLOSION HAZARD.** Fitting caps may exceed 10 pF. When handling A3 or A2L avoid handling the fitting caps when machine is operating.
8. **WARNING: EXPLOSION HAZARD.** When handling A3 or A2L refrigerants, operator must take all appropriate measures to avoid electrostatic discharge (ESD) to the machine or to other earthed objects in the Temporary Hazardous Zone.

1. Electrical shock risk - Do not operate in wet environments, rain, or around any liquids.
10. NOTICE: Risk of Property Damage. The use of an undersized extension cord may cause voltage to drop resulting in power loss to the motor and overheating. Use 14 AWG (2.5 mm<sup>2</sup>) or thicker, up to 50 feet (15 m).
11. Always wear Proper Protective Equipment (PPE), which includes gloves, safety glasses and earplugs.
12. Know proper safety and handling requirements of the refrigerant in the Safety Data Sheet (SDS).
13. Avoid breathing refrigerant and oil vapors. Inhalation of high concentrations of refrigerant vapor can block oxygen to the brain causing injury or death.
14. Handle hoses and equipment carefully as refrigerant may be under high pressure. Exposure to refrigerant can cause frostbite.
15. Perform leak detection in accordance with recommended practice to verify working environment is free from leaking refrigerant as it can be toxic and/or flammable.
16. Only work in well-ventilated areas (minimum of 6 air exchanges per hour).
17. Avoid cross contamination by not mixing refrigerants.
18. Oil from the vacuum pump can be hot. Handle with caution.
19. Inspect this machine prior to use. Do not use if there is obvious damage to the enclosure such that fingers or metallic objects might enter the casing.

 **WARNING: EXPLOSION HAZARD. This device is intended to be used strictly as a vacuum pump. Below are additional safety instructions for handling A2L & A3 refrigerants with other equipment.**

1. Adhere to local occupational safety codes and possess detailed knowledge and skills when handling flammable refrigerants.
2. Have emergency, evacuation, and fire protection plans.
3. Designate and monitor a Temporary Hazard Zone with a 10 foot/ 3-meter perimeter. Identify and disable all possible ignition sources within this zone. Monitor air to verify refrigerant levels stay below hazardous levels as specified in Safety Data Sheet (SDS). Use a ventilation fan to maintain 6

air exchanges per hour within this zone.

4. Outside of the Temporary Hazard Zone, ensure device(s) power is switched OFF ( O ) before connecting and locking the power cord onto the unit(s). Connect any other equipment and connect to the main power.
5. When an extension cord outlet is within the Temporary Hazardous Zone, it is recommended that users use a cord cover, or similar device, to reduce / eliminate the possibility of accidentally unplugging from the extension cord while the circuit is live.
6. For battery powered devices, recharge or replace batteries outside of the Temporary Hazard Zone.
7. When using a recovery tank, bond the outlet port to the recovery tank's unpainted fitting with a grounding strap to dissipate static electricity.
8. Ensure area around machine is free of debris that could enter air vents and fan and cause accidental sparking.
9. Always remain in attendance and observant when equipment is operating.
10. Do not mix flammable refrigerants with air.
11. If system has a suspected leak, stop recovery at 0 psig/bar to prevent air from entering the recovery tank.
12. Use an evacuated recovery tank that complies with local regulations.
13. After recovery, purge system with 100% nitrogen before opening system for repair.

 **CAUTIONS – Failure to heed these conditions can cause equipment damage.**

1. Ensure that all equipment is in good working condition.
2. If the power cable is damaged, it must be replaced with service parts from the manufacturer.
3. Avoid cross contamination by not mixing refrigerants.
4. Ensure fan opening is clear of debris.
5. Prevent prolonged exposure to direct sunlight. Store indoors.
6. This device should only be used for evacuation of refrigerant systems after refrigerant has been removed from the system and the system has been opened to atmosphere. This device is not to be used as a transfer pump for liquid media, doing so can damage the product.
7. The unit must be protected against severe impact. Solid objects must not be allowed to fall onto the unit.

# Safety Information

## Vacuum Pump Protection

1. Ensure clean oil is added to a level between MIN and MAX lines.
2. Do not use to remove refrigerant from a system. Use a recovery machine and filter to remove refrigerant and particles from the system before using VP633/VP833/VPX33 to evacuate the system.
3. Do not use on pressurized systems. Doing so may damage or contaminate your vacuum pump.
4. Do not use on ammonia or salt water systems. Doing so may damage or contaminate your vacuum pump.
5. Store with ports capped to prevent dust from entering.
6. Drain oil after every job and store VP633/VP833/VPX33 empty to prevent spillage and reduced oil life.

## Setup

1. Inspect the machine and ensure there is no physical damage.
2. RISK OF EXPLOSION. DANGER: When working with A2L or A3 refrigerants, first ensure motor power is switched OFF ( 0 ) before connecting and locking the power cord onto the vacuum pump, continue by connecting the main power. Connect any other equipment outside of the Temporary Hazard Zone.
3. Ensure power cord is not damaged and all equipment is grounded.
4. NOTICE: Risk of Property Damage. The use of an undersized extension cord may cause voltage to drop resulting in power loss to the motor and overheating. Use 14 AWG (2.5 mm<sup>2</sup>) or thicker, up to 50 feet (15 m). DO NOT USE 18 AWG (0.75 mm<sup>2</sup>)!
5. Ensure extension cord is grounded, 3 conductor, and is not damaged.
6. Use the correct AC plugging procedure (unit first, wall socket second).
7. Use the correct AC unplugging procedure (wall socket first, unit second).
8. DO NOT disconnect the AC cord from the unit while the cord is still plugged in to mains power, even if the unit is turned OFF ( 0 ).
9. The main power receptacle must be located outside any areas that may potentially contain an explosive atmosphere; that is, outside the Temporary Hazard Zone area(s).

## IEC Power Cord with Screw Locks

For protection, the vacuum pump includes a screw lock for the unit's power cord.

1. With the unit switched OFF ( 0 ), twist the wire lock upwards and plug the female end of the power cord into the unit.
2. Twist the wire lock down over the power cord and use a screwdriver to tighten the screws and lock into place.
3. Connect to the main power.

## Grounding Instructions

This product must be grounded. In the event of an electrical short circuit, grounding reduces the risk of electric shock by providing an escape wire for the electric current. This product is equipped with a cord having a grounding wire with an appropriate grounding plug. The plug must be plugged into an outlet that is properly installed and grounded in accordance with all local codes and ordinances.

**WARNING** – Improper installation of the grounding plug may result in a risk of electric shock. Check with a qualified electrician or serviceman when the grounding instructions are not completely understood, or when in doubt as to whether the product is properly grounded.

Do not modify the plug provided; if it does not fit the outlet, have the proper outlet installed by a qualified electrician.

Not recommended to use with a GFI outlet. Circuit may trip, causing vacuum to stop.

# Specifications

**Flow Rate:** VP633; 6 CFM (170 l/min), VP833; 8 CFM (225 l/min), VPX33; 10 CFM (280 l/min)

**Ultimate Vacuum at Input Ports:** 15 Microns

**For Use With:** A3, A2L, and A1 Refrigerants

**Not for Use With:** R-702, R-717

**Certification:** Class I, Division 2, Groups C-D, T4  
 $32^{\circ}\text{F} (0^{\circ}\text{C}) \leq T_{\text{AMB}} \leq 104^{\circ}\text{F} (40^{\circ}\text{C})$

**Oil Capacity:** 8 oz (237ml)

**Oil Compatibility:** Fieldpiece Vacuum Pump Oil (Highly refined and optimized for proper sealing and lubrication)

**Oil Backlight:** Blue LED

**Oil Drain:** Ball Valve

**Port Sizes:** (1) 1/4", (2) 3/8", (1) 1/2"

**Compressor:** Rotary Vane, Two Stage

**Motor:** 1/2 HP AC (VP633), 3/4 HP Brushless DC (VP833/VPX33)

**RPM:** 2866 (VP633 ~ 50 Hz), 2500 (VP833/VPX33)

**Power Source:** 120 VAC @ 60 Hz

**Nominal Current Draw:** 5A @ 120 VAC

**Nominal Power:** 600W @ 120V

**Unit Ingress Protection Rating:** IP20

**Dimensions:** 7.9" x 11.7" x 16.0" (201 mm x 296 mm x 406 mm)

**Weight Empty:** 33 lb / 15 kg (VP633), 29 lb / 13 kg (VP833),  
26 lb / 12kg (VPX33)

**Operating Environment:** 32°F to 104°F (0°C to 40°C)

**Noise per EN ISO 2151:2008:** Sound pressure level at working station  
60.5 dB(A), K = 3 dB(A)

Sound power level 72.8 dB(A), K = 3 dB(A)

**US Patents:** [www.fieldpiece.com/patents](http://www.fieldpiece.com/patents)

# Certifications



**Class I, Division 2, Groups C-D, T4**  
 $32^{\circ}\text{F} (0^{\circ}\text{C}) \leq T_{\text{AMB}} \leq 104^{\circ}\text{F} (40^{\circ}\text{C})$

Complies with: CSA-C22.2 No.68-18 and UL 1450-4th Edition,  
UL 121201 Class I, Division 2 and CSA C22.2 No. 213



FCC/ISED Compliance Statements

Note: This equipment has been tested and found to comply with the limits for a Class A digital device, pursuant to part 15 of the FCC Rules. These limits are designed to provide reasonable protection against harmful interference when the equipment is operated in a commercial environment. This equipment generates, uses, and can radiate radio frequency energy and, if not installed and used in accordance with the instruction manual, may cause harmful interference to radio communications. Use of this equipment in a residential setting may cause temporary radio communication interference. Please note that changes or modifications not expressly approved by the party responsible for compliance could void the user's authority to operate the equipment.



Restriction of Hazardous  
Substances Compliant



Waste Electrical and Electronic Equipment  
Do not dispose through typical waste streams.

**WARNING:** Cancer and Reproductive Harm - [www.P65Warnings.ca.gov](http://www.P65Warnings.ca.gov)

# Description

Performing a proper system evacuation prior to charging directly increases the expected life and efficiency of the system. Fieldpiece vacuum pumps provide a quick, clean, and easy way to get the job done fast.

Good oil is the lifeblood of every evacuation. Fieldpiece vacuum pumps have a huge, backlit window on the oil tank to let you clearly see the condition of the oil and the fill level.

With the Fieldpiece RunQuick® Oil Change System you can replace the oil in under 20 seconds without losing vacuum, even while the pump is running. And the extra wide base helps prevent tipping and spilling oil.

Four inline ports in three different sizes give you easy hose routing and connection. The power cord can be placed on the handle for tangle free storage.

Fieldpiece vacuum pumps are durable, lightweight, and portable for easy carrying to and from the job site.

## What's Included

VP633, VP833, or VPX33 Vacuum Pump

IEC Power Cord

(2) 8 Ounce Vacuum Pump Oil Bottles

Operator's Manual

1 Year Warranty

## Features

- **VP633; 6 CFM (170 l/min), VP833; 8 CFM (225 l/min), VPX33; 10 CFM (280 l/min)**
- **A3, A2L and A1 Compatible**
- **Certified for Class I, Division 2 Hazardous Locations**
- **Ultimate Vacuum 15 Microns**
- **RunQuick® Oil Change System**
  - Easy View Window and Oil Backlight
  - Change Oil Quickly, Even with the Pump Running
  - Extra Oil Bottle Storage
  - Elevated Oil Drain Ball Valve
  - Wide Mouth Fill Port
  - Oil Bottle Cap Storage
  - Precision Oil Circulator
- **4 Inline Ports**
  - (1) 1/4"
  - (2) 3/8"
  - (1) 1/2"
- **Two Stage Pump**
- **Gas Ballast Switch**
- **LED Indicators**
- **Remote Exhaust Port**
- **Quiet Fan-Cooled Operation**
- **1/2 HP AC Motor (VP633)**
- **3/4 HP Brushless DC Motor (VP833,VPX33)**
- **Cord Storage Integrated into Rubber Handle**
- **IEC Power Cord with Screw Lock**
- **EPO Coated Aluminum Pump (VPX33)**
  - Super Lightweight
  - Enhanced Durability

# Tech Tips

## General

1. Vacuum pumps are not refrigerant recovery machines and should not be used for recovering refrigerant.
2. Purge the A/C system with a few psi of dry nitrogen before evacuation to pre-dry the system. This extra step actually saves time overall because it quickly removes a great amount of moisture, oil, and other contaminants before you even connect your pump.
3. Performing a triple evacuation is a great way to ensure a system is dry. The nitrogen flow can help carry moisture with it out of the system. A triple evacuation is as follows:
  1. Purge with nitrogen
  2. Evacuate down to 2000 microns
  3. Purge with nitrogen
  4. Evacuate down to 1000 microns
  5. Purge with nitrogen
  6. Evacuate down to below 500 microns.
4. Always use fresh Fieldpiece Vacuum Pump Oil. If oil is left in the pump for more than a week, the oil may have absorbed enough moisture from ambient air to affect performance.
5. Refrigerant manifolds can be convenient to charge the system after evacuation, but their hoses and valves can limit or slow evacuation. It's best to use vacuum rated hoses, directly connected to valve core removal tools at the service ports.
6. If you want to use a manifold, it's best to use a 4 port manifold. 4 port manifolds typically have a larger bore to increase flow. They also isolate the pump from the system and micron gauge without the need of a shut-off valve on the hose.

7. Hoses:
  - Shortest length possible.
  - Widest diameter possible.
  - Vacuum rated.
  - Core depressors removed.
  - Ball valve shut-offs instead of low loss fittings.
  - Good seals.
  - Replace if worn.
8. Use a vacuum rated Schrader valve core removal tool to temporarily remove valve cores from service ports.
9. Connect multiple hoses to the inline ports on VP633/VP833/VPX33 to further decrease hose restriction and increase air flow.

## Cold Weather Starts

1. Open an unused input port to ambient for a few seconds until the pump is running.
2. Warm the pump in your truck/home by letting it sit in a warm environment. You can warm the oil in your truck/home before adding it to the pump.

# Operation

Gas Ballast Valve (Open)  
IEC Power Cord Inlet with Screw Lock  
Motor Power Switch (OFF / 0)

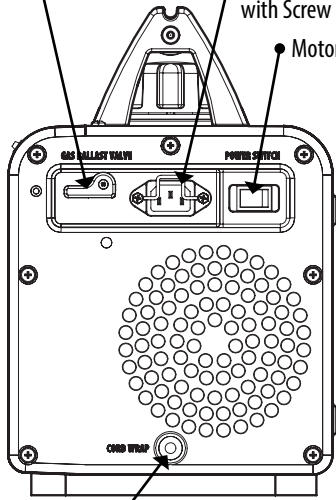

Power Cord Storage Wrap

Remote Exhaust Collar

Power Cord Storage

Backlit Oil Window and Tank Access (4 Screws)  
LED Indicators

4 Input Ports

Oil Tank Cap

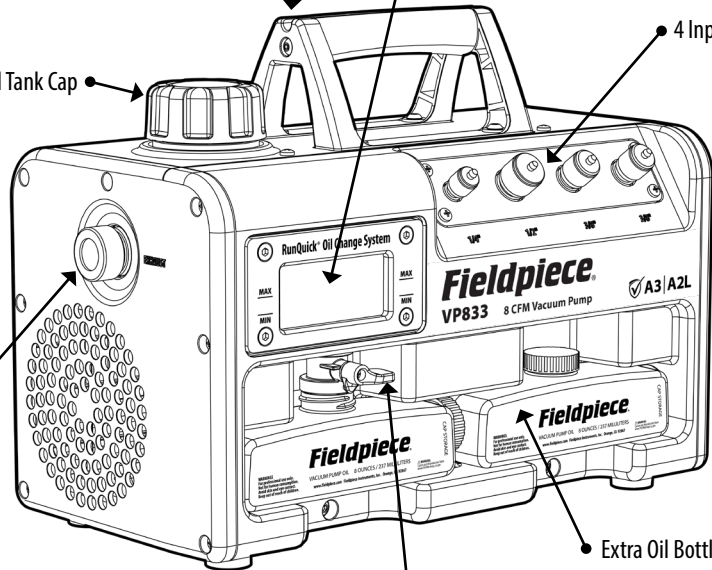

Oil Drain Valve (CLOSED)

# RunQuick® Oil Change System

The only way to create a deep vacuum is to evacuate with fresh oil, especially at the end of the job. The RunQuick® oil change system makes this old chore a breeze.

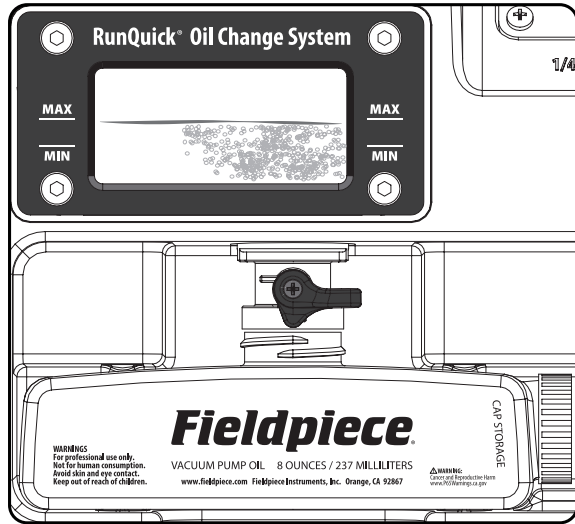

## Easy View Window and Oil Backlight

There are a few signs that remind you to change your oil. The visual condition is one of them. If it looks old, change it. You will see tiny air bubbles with fresh oil. Saturated oil will look more opaque.

## Elevated Oil Drain Ball Valve

By elevating the oil reservoir and utilizing a fast opening ball valve, we made it easy to drain old oil into the empty bottle without a drop spilled.

## Oil Bottle Cap Storage

When you open a fresh bottle of oil, put the cap on the side of the bottle so you can cap the bottle after you drain old oil into it.

## Wide Mouth Fill Port

It is easy to hit your target with the wide mouth fill port.

## Change Oil Quickly with the Pump Running

Towards the end of the evacuation is when you need fresh oil the most. The RunQuick® system maintains a vacuum for about 30 seconds after you drain the oil so you can drain and pump without any loss of vacuum.

## Precision Oil Circulator and Fan

Instead of submerging the pump in excess oil, a small oil pump constantly lubricates targeted sealing zones. The quiet high speed fan cools the heat sinks of the motor and pump.

## Spare Oil Bottle Storage

Take an extra bottle to and from the job site so you always have that fresh oil performance bump at the end of the job.

## Evacuation with a 4 Port Manifold

This is the most common evacuation method. Read Tech Tips (page 14) for optimum gauge placement and variations to reduce recovery times.

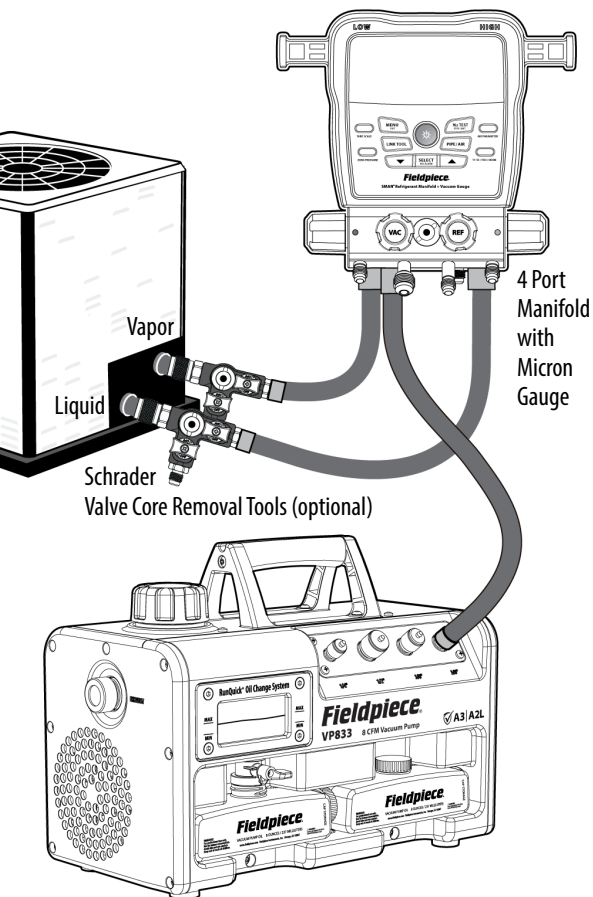

1. Always fill with fresh Fieldpiece Vacuum Pump Oil (page 26).  
*Running the pump without oil will damage the pump and void the warranty. Oil can be drained while the pump is running if refilled within 3 minutes (within 30 seconds to maintain your vacuum).*
2. **WARNING: EXPLOSION HAZARD.** Ensure the motor power switch is turned OFF ( 0 ) before connecting and locking the power cord onto the vacuum pump. See **Setup** on page 8.
3. Plug into a matching power outlet (oil backlight should illuminate) outside the Temporary Hazard Zone.
4. Ensure the gas ballast is closed (vertical) (page 28).
5. Connect to the empty, depressurized A/C system.
6. Turn the motor power switch to ON ( 1 ).
7. Open line set (hoses, manifolds, removal tools, etc.) to expose the pump to the system.  
**To reduce oil contamination:** *Open the gas ballast valve (page 28) until the dehydration process is mostly complete (typically 2000-3000 microns), then close the gas ballast valve. The yellow LED in the oil window shines if the ballast is open.*
8. After the appropriate vacuum is reached, isolate the system from the pump. You can check the system for potential leaks at this time by monitoring your micron gauge.  
*Your vacuum pump has a unique oil suck back prevention feature to keep your hoses clear of oil. Still, it's good practice to release the vacuum at the input port before turning off the pump.*
9. Turn the motor power switch to OFF ( 0 ), remove your hoses, and cap the ports to keep components free of contaminants.
10. **WARNING: EXPLOSION HAZARD.** Disconnect from the system and unplug from power (wall socket first, unit second).
11. Drain the contaminated oil while the oil is still warm to keep the pump as clean as possible when stored.

## Evacuation with a 3 Port Manifold

This is a common, but less than ideal evacuation method. Read Tech Tips (page 14) for optimum gauge placement and variations to reduce recovery times.

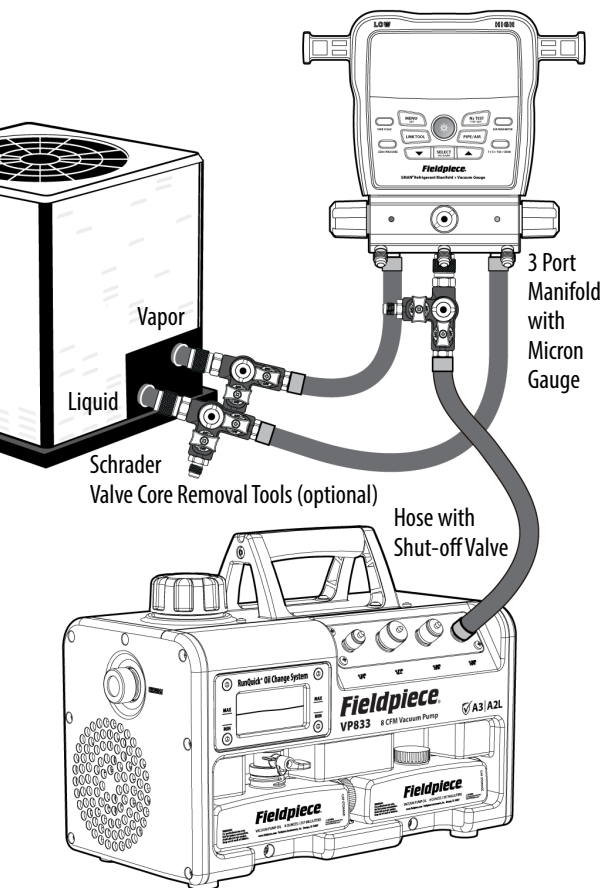

1. Always fill with fresh Fieldpiece Vacuum Pump Oil (page 26).  
*Running the pump without oil will damage the pump and void the warranty. Oil can be drained while the pump is running if refilled within 3 minutes (within 30 seconds to maintain your vacuum).*
2. **WARNING: EXPLOSION HAZARD.** Ensure the motor power switch is turned OFF ( 0 ) before connecting and locking the power cord onto the vacuum pump. See **Setup** on page 8.
3. Plug into a matching power outlet (oil backlight should illuminate) outside the Temporary Hazard Zone.
4. Ensure the gas ballast is closed (vertical) (page 28).
5. Connect to the empty, depressurized A/C system.
6. Turn the motor power switch to ON ( 1 ).
7. Open line set (hoses, manifolds, removal tools, etc.) to expose the pump to the system.  
**To reduce oil contamination:** *Open the gas ballast valve (page 28) until the dehydration process is mostly complete (typically 2000-3000 microns), then close the gas ballast valve. The yellow LED in the oil window shines if the ballast is open.*
8. After the appropriate vacuum is reached, isolate the system from the pump. You can check the system for potential leaks at this time by monitoring your micron gauge.  
*Your vacuum pump has a unique oil suck back prevention feature to keep your hoses clear of oil. Still, it's good practice to release the vacuum at the input port before turning off the pump.*
9. Turn the motor power switch to OFF ( 0 ), remove your hoses, and cap the ports to keep components free of contaminants.
10. **WARNING: EXPLOSION HAZARD.** Disconnect from the system and unplug from power (wall socket first, unit second).
11. Drain the contaminated oil while the oil is still warm to keep the pump as clean as possible when stored.

## Direct Evacuation

This is usually the fastest evacuation method. Read Tech Tips (page 14) for optimum gauge placement and variations to reduce recovery times.

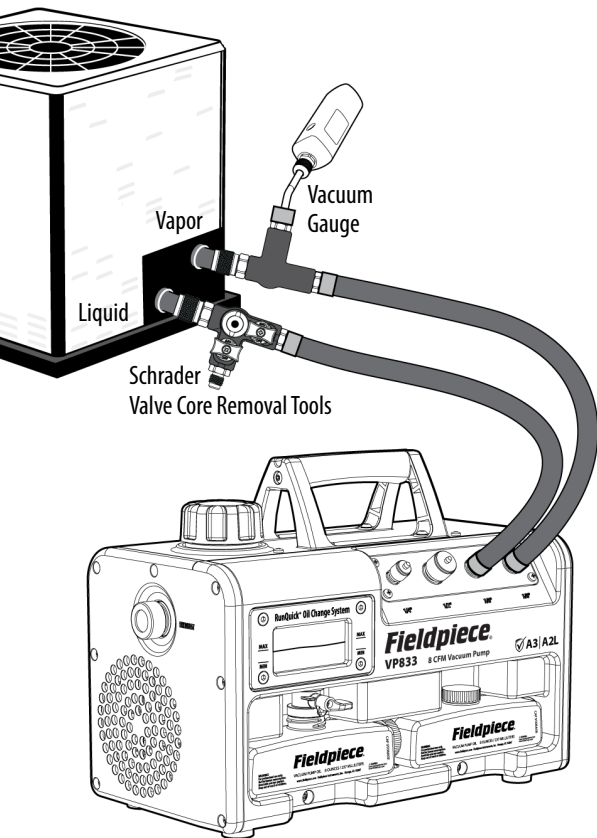

1. Always fill with fresh Fieldpiece Vacuum Pump Oil (page 26).  
*Running the pump without oil will damage the pump and void the warranty. Oil can be drained while the pump is running if refilled within 3 minutes (within 30 seconds to maintain your vacuum).*
2. **WARNING: EXPLOSION HAZARD.** Ensure the motor power switch is turned OFF (0) before connecting and locking the power cord onto the vacuum pump. See **Setup** on page 8.
3. Plug into a matching power outlet (oil backlight should illuminate) outside the Temporary Hazard Zone. Ensure the gas ballast is closed (vertical) (page 28).
4. Connect to the empty, depressurized A/C system.
5. Turn the motor power switch to ON (1).
6. Open line set (hoses, manifolds, removal tools, etc.) to expose the pump to the system.  
**To reduce oil contamination:** *Open the gas ballast valve (page 28) until the dehydration process is mostly complete (typically 2000-3000 microns), then close the gas ballast valve. The yellow LED in the oil window shines if the ballast is open.*
7. After the appropriate vacuum is reached, isolate the system from the pump. You can check the system for potential leaks at this time by monitoring your micron gauge.  
*Your vacuum pump has a unique oil suck back prevention feature to keep your hoses clear of oil. Still, it's good practice to release the vacuum at the input port before turning off the pump.*
8. Turn the motor power switch to OFF (0), remove your hoses, and cap the ports to keep components free of contaminants.
9. **WARNING: EXPLOSION HAZARD.** Disconnect from the system and unplug from power (wall socket first, unit second).
10. Drain the contaminated oil while the oil is still warm to keep the pump as clean as possible when stored.

# Oil Change Procedure

Changing oil is easy to perform. Start each job with fresh oil. Change as needed during the job. It is recommended to drain the oil during storage. Always dispose of oil according to local jurisdiction.

## ADDING FRESH OIL

1. Ensure the drain valve is closed (horizontal).
2. Unscrew the pump's oil fill cap 1/4 turn counter clockwise.
3. Open a new 8 ounce bottle of Fieldpiece Vacuum Pump Oil (OIL8X3). Put the bottle cap on the side of the bottle (CAP STORAGE).
4. Pour the entire 8 ounce bottle of fresh oil into the oil port and ensure the oil level is between the MIN and MAX lines indicated on the window bezel. Replace oil fill cap.
5. Place the empty bottle under the drain valve so it's ready to gather used oil during the next oil change.
6. Your vacuum pump is now ready to operate.

## CHANGING OIL WITH THE PUMP RUNNING

The RunQuick® system maintains a vacuum for about 30 seconds after you drain the oil. *Running the pump for longer than 30 seconds after draining oil could exceed Class I, Division 2 temperature limits, could damage the pump, and will void the warranty.*

1. Ensure an empty oil bottle is located under the oil drain.
2. Open the oil drain valve clockwise (vertical) to empty the oil reservoir of old oil.
3. Close the valve counter clockwise (horizontal).
4. Unscrew the pump's oil fill cap 1/4 turn counter clockwise.
5. Open a new 8 ounce bottle of Fieldpiece Vacuum Pump Oil (OIL8X3). Put the bottle cap on the side of the bottle (CAP STORAGE).
6. Pour the entire 8 ounce bottle of fresh oil into the oil port and ensure the oil level is between the MIN and MAX lines indicated on the window bezel. Replace oil fill cap.
7. Remove and cap the old oil for disposal.
8. Place the empty bottle under the drain valve so it's ready to gather used oil during the next oil change.

## DRAINING OIL AT END OF JOB

1. For extended pump life, drain the oil immediately after the job instead of waiting until the beginning of the next job.
2. Ensure the pump oil inside is warm enough, > 75°F (> 24°C), for proper drainage. Run the pump for 10 minutes if ambient temp is low.
3. Ensure the motor power switch is turned OFF ( 0 ).
4. Plug into power to activate the oil backlight.  
*For A2L or A3 refrigerants, follow the correct plugging/unplugging procedures. See Setup on page 8.*
5. Ensure your old empty oil bottle is located under the oil drain.
6. Open the oil drain valve clockwise (vertical) to empty the oil reservoir of old oil.
7. Close the valve counter clockwise (horizontal).
8. Remove and cap the old oil for disposal.

# Dynamic Vacuum Measurement

During the pull down, the system's vacuum level drops faster at the front of the system, near the vacuum pump.

To ensure that your full system achieves the target micron level, place the vacuum gauge as far to the back of the system, away from the pump, as possible.

## Remote Exhaust

Unscrew the brass collar on the EXHAUST port and connect an obstruction-free garden hose if you need to exhaust oil mist and vapor remotely to the outside of a building structure.

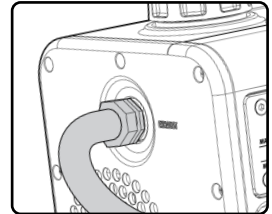

# Gas Ballast Valve Switch

Much of the air and moisture in a system are removed before reaching 3000 microns. For wet systems, you should open the gas ballast during this initial pull down. Doing so helps the pump run smoothly and keeps the oil in good condition for when you need it most -- towards the end of the evacuation.

When the dehydration process is mostly complete (typically 2000-3000 microns), close the gas ballast valve so that a deep vacuum can be generated.

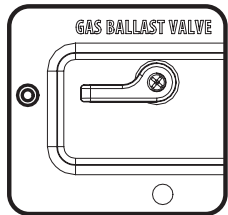

## Open

- Set here for initial pumping down (above 3000 microns) of wet systems.
- Yellow window LED shines.
- Discharge stroke exposed to ambient.

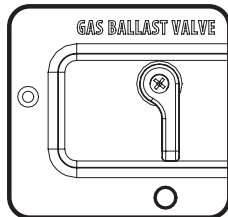



## Closed

- Normal operating position.
- Yellow window LED off.
- Discharge stroke isolated from ambient.

# LED Indicators

Three columns of LEDs in the oil window indicate various states. The blue lights of the right column indicate power is connected. The blue lights of the middle column shine when the pump is switched on. The LEDs of the left column typically indicate the gas ballast valve is open.

		
SPECIAL MESSAGE (Y/R)	SWITCHED ON (2 BLUE)	PLUGGED IN (2 BLUE)

## Special Messages

**Yellow Blink (VP833/VPX33)/ Solid Yellow LED (VP633):**  
Gas ballast valve open.

**Yellow Blink + Red Blink (VP833/VPX33):**  
Low voltage detected.

**Red Blink (VP833/VPX33):**  
High voltage detected.

**Red Solid (VP833/VPX33):**  
Internal fault detected.

# Maintenance

## General

This machine is not intended for use by persons (including children) with reduced physical, sensory or mental capabilities, or lack of experience and knowledge, unless they have been given supervision or instruction concerning use of the machine by a person responsible for their safety.

Children should be supervised to ensure that they do not play with the machine.

Wipe with damp cloth to clean the exterior. Do not use solvents.

## Storage

Empty or replace oil at the end of every job. Don't leave old oil in the machine. Store the pump and oil in dry clean areas for longest life.

Oil can lose its sealing properties if left uncovered. Keep oil sealed until it's ready for use.

## Vacuum Isolation Test

Perform this test to ensure your vacuum pump and your micron gauge are working properly.

1. Connect your vacuum gauge *directly* to a port on your pump.
2. Seal the 3 other ports.
3. Ensure the gas ballast is closed (page 28).
4. Switch your pump ON to create a vacuum at your gauge.

If your gauge measures below 200 microns within 1 minute, you know your vacuum pump *and* micron gauge are working correctly.

If your gauge does not reach 200 microns, there is a problem with your gauge, vacuum pump, or both.

## Oil Window Cleaning

It's important to see the condition of your oil as well as the LED indicators located in the oil reservoir.

The large oil drain ball valve will typically drain solids and sludge when changing the oil. When it becomes hard to see through the window, you can remove the oil window for easy cleaning.

1. Turn the motor power switch to OFF ( 0 ) and unplug it from the power source.
2. Ensure oil is drained from the reservoir.  
*To reduce residual oil spillage, do not lay the pump on its side.*
3. While holding the black bezel (frame) in place, use a TORX® bit (T25) to remove the 4 hex socket screws.
4. While holding the glass oil window in place, remove the black bezel and notice the O-ring located behind the window.
5. Slowly remove the glass oil window while making sure to locate and remove the O-ring seal.
6. Wipe away any spilt oil, but leave a bit of oil on the O-ring to ensure a good seal.
7. Clean the glass oil window and set aside to dry.
8. If desired, you can use a light bristle brush clean out the oil reservoir itself, but performance is rarely affected by a dirty reservoir.
9. Place the O-ring back into its groove.
10. Place the glass oil window over O-ring and hold in place.
11. Reinstall the bezel over the glass oil window using the 4 hex socket screws. *To avoid breaking the window, start all 4 screws before hand-tightening any of them. Do not overtighten.*

# Troubleshooting

## **Appropriate vacuum is never reached.**

Ensure the gas ballast is closed (vertical position, yellow LED off).

Ensure oil is fresh and oil level is between MIN and MAX lines.

Ensure all port caps are closed and have working seals.

Limit amount of connections. Check for leaks at connections.

Use vacuum rated hoses.

Check for blockages between the pump and the system.

Check for a system leak. Check all hoses, fittings, and seals for leakage.

Verify your vacuum gauge is in the correct location and is accurate.

Check pump CFM is right for system size. Flow rate impacts time to reach vacuum.

Perform a triple evacuation to carry moisture out of the system by purging the system with dry nitrogen.

## **Vacuum rises when isolating the system.**

Ensure your micron gauge is located on the system side of the shut-off valve.

The micron gauge of a 3 port (2 valve) manifold cannot measure a system's vacuum if the valves are closed. Use a shut-off valve at the third port to isolate the pump from the system (page 22).

Check for a system leak. Check the fitting gasket. It shall be in good condition and flush.

## **Oil backlight is not lit when plugged in.**

Ensure power cord and outlet are functional and that source voltage matches the pump. If backlight does not shine and the pump turns on, the oil backlight LED module may need to be replaced.

## **Pump makes excessive noise.**

The pump may be experiencing a high load.

Loose objects may be vibrating in the case.

Motor bearings may be bad. Motor needs to be replaced.

Motor may have come loose. Tighten motor mount bolts.

Oil level or condition may be bad. Change the oil.

Leaks may be present. Tighten or fix all connections.

## **Oil mist is coming out of the exhaust.**

Some slight oil mist is normal due to airflow carrying oil as it passes through, and out of the pump. You can attach a garden hose to the exhaust port to control oil misting (page 27).

For larger systems with long evacuation times, extended high pressure conditions can cause excessive misting to occur. Add oil as needed if excessive oil loss occurs.

## **Motor does not start when switched ON.**

Models VP833/VPX33 have a soft-start feature that slowly increases speed during startup. Slow startup in cold temperatures is normal.

Oil in the pump may have become overly viscous due to contamination or low temperature. Use fresh Fieldpiece Vacuum Pump Oil within the pump's operating temperature.

The pump may be cold. Warm the pump in your truck/home by letting it sit in warm environment. You can warm the oil in your truck/home before adding it to the pump.

The pump may be cold. Open an unused input port to ambient for a few seconds until the pump is running.

Voltage is incorrect. Ensure proper cord length and that source voltage matches the pump.

Motor may be damaged. Motor needs to be replaced.

Motor thermal protection activated. Wait for the machine to cool down to operating range and determine why it may have overheated. Loading may be excessive.

Not recommended to use with a GFI outlet. Circuit may trip, causing vacuum to stop.

## **Oil is leaking around base.**

Oil likely fell into the housing from around the fill port and is now dripping through the internal housing. Wipe clean and make sure oil is not spilled when adding to the wide mouth oil fill port.

# Limited Warranty

This machine is warranted against defects in material or workmanship for one year from date of purchase from an authorized Fieldpiece dealer. Fieldpiece will replace or repair the defective unit, at its discretion, subject to verification of the defect.

This warranty does not apply to defects resulting from abuse, neglect, accident, unauthorized repair, alteration, or unreasonable use of the machine.

Any implied warranties arising from the sale of a Fieldpiece product, including but not limited to implied warranties of merchantability and fitness for a particular purpose, are limited to the above. Fieldpiece shall not be liable for loss of use of the machine or other incidental or consequential damages, expenses, or economic loss, or for any claim of such damage, expenses, or economic loss.

Local and national laws vary. The above limitations or exclusions may not apply to you.

## Obtaining Service

Visit [www.fieldpiece.com/rma](http://www.fieldpiece.com/rma) for the latest information on how to obtain service in the U.S. and Canada.

For customers outside the U.S., warranty for products should be handled through local distributors.

Visit [www.fieldpiece-europe.com/store-locator](http://www.fieldpiece-europe.com/store-locator) for local distributors in Europe.

## Supplier's Declaration of Conformity 47 CFR § 2.1077 Compliance Information

**Unique Identifier:** VP633 / VP833 / VPX33

### **Responsible Party – U.S. Contact Information:**

Fieldpiece Instruments  
1636 West Collins Ave.  
Orange, CA  
92867

714-634-1844 | [fieldpiece.com](http://fieldpiece.com)

### **FCC Compliance Statement**

This device complies with Part 15 of the FCC Rules. Operation is subject to the following two conditions: (1) This device may not cause harmful interference, and (2) this device must accept any interference received, including interference that may cause undesired operation.

# ***VP633***

# ***VP833***

# ***VPX33***

**Scan the QR code to visit your Fieldpiece website and register your product.**



US, CA, MX

